



Merge Cardio™

12.1

WORKSTATION DICOM CONFORMANCE STATEMENT

© Copyright IBM Corporation 2021.

The content of this document is confidential information of Merge Healthcare Incorporated and its use and disclosure is subject to the terms of the agreement pursuant to which you obtained the software that accompanies the documentation.

Merge Healthcare® is a registered trademark of Merge Healthcare Inc.

The Merge Healthcare logo is a trademark of Merge Healthcare Inc.

All other names are trademarks or registered trademarks of their respective companies.

U.S. GOVERNMENT RESTRICTED RIGHTS:

This product is a “Commercial Item” offered with “Restricted Rights.” The Government's rights to use, modify, reproduce, release, perform, display or disclose this documentation are subject to the restrictions set forth in Federal Acquisition Regulation (“FAR”) 12.211 and 12.212 for civilian agencies and in DFARS 227.7202-3 for military agencies. Contractor is Merge Healthcare.

INDICATIONS FOR USE:

Merge Cardio software product is an integrated multi-modality image and information system designed to perform the necessary functions required for import, export, review, analysis, quantification, reporting, and data management of digital cardiovascular images, documents, and data related to cardiology.

Merge Cardio offers support for third-party applications in order to enable the use of commercially available tools and specified applications for analysis, quantification, and reporting.

Merge Cardio software runs on standard information technology hardware and software, using standard information technology operating systems and user interfaces. Communication and data exchange are done using standard protocols.

The modular design allows configurability to tailor the image import and communications solution to the needs of the user. The number of modalities and reporting and/or viewing sites can be configured per system.

If you experience a serious incident that has occurred in relation to this medical device, please report the incident to Watson Health or the regulatory authority in your country.



Merge Healthcare Incorporated
900 Walnut Ridge Drive
Hartland, WI 53029

Symbols Glossary:

Symbol	Title
	Manufacturer

The full symbols glossary can be viewed at <https://www.ibm.com/support/pages/node/6262453>.

INSTRUCTIONS FOR USE:

Instructions for use are available electronically in PDF format. Paper format can be requested for supported languages by contacting Customer Support and will be provided free of charge within seven calendar days of receiving the request. The paper format can also be provided at the time of delivery if so requested at the time of order.

For application support or to report issues with user documentation, contact Customer Support:

- ☎ 1-877-741-5369 (North America)
+31.20.514.5073 (Europe, the Middle East and Africa)
1800 316 746 (Australia)

✉ WHISupport@us.ibm.com

Part	Date	Revision	Description
VRCS-22739	January 2021	2.0	Release 12.1.

The latest version of this document can be found at <https://mergecustomer.force.com/mergeusercommunity/login>.

Contents

- Preface 5
 - Operational Precautions 5
- Chapter 1. Introduction 6
 - 1.1. Audience 6
 - 1.2. Terminology 6
 - 1.3. Related Documents 6
- Chapter 2. Network Conformance Statement 7
 - 2.1. Introduction 7
 - 2.2. Implementation Model 7
 - 2.2.1. Application Data Flow Diagram 7
 - 2.2.2. Functional Definition of Application Entities (AE) 8
 - 2.2.3. Sequencing of Real-World Activities 9
 - 2.3. Application Entity Specifications 10
 - 2.3.1. Workstation DICOM AE Specification 10
 - 2.4. Association Initiation Policies 12
 - 2.4.1. General 12
 - 2.4.2. Association Initiation Policy 13
 - 2.4.3. Real-World Activity “User Selects DICOM Echo” 13
 - 2.4.4. Proposed Presentation Contexts 15
 - 2.4.5. Association Acceptance Policy 26
 - 2.5. Communication Profiles 38
 - 2.5.1. Supported Communication Stacks (parts 8,9) 38
 - 2.5.2. TCP/IP Stack 38
 - 2.5.3. API 38
 - 2.5.4. Physical Media Support 38
 - 2.6. Extensions/Specializations/Privatizations 38
 - 2.6.1. Standard Extended/Specialized Private SOP 38
 - 2.6.2. Private Transfer Syntaxes 38
 - 2.7. Configuration 39
 - 2.7.1. Support of Extended Character Sets 39
- Chapter 3. SC Information Object Implementation 40
 - 3.1. Introduction 40
 - 3.2. SC Image IOD Implementation 40
 - 3.3. SC Image IOD Entities 40

3.3.1.	Entities Description	40
3.4.	SC Image IOD Module Table.....	40
3.5.	Information Module Definitions.....	41
3.5.1.	Patient Entity Module.....	41
3.5.2.	Study Entity Module	42
3.5.3.	Series Entity Module	42
3.5.4.	Equipment Entity Module.....	43
3.5.5.	Image Entity Module	44
Chapter 4.	Print Management Specific Modules	47
4.1.	Introduction	47
4.1.1.	Basic Film Session Presentation Module Attributes	47
4.1.2.	Basic Film Box Presentation Module Attributes	47
4.1.3.	Image Box Pixel Presentation Module Attributes	48
Chapter 5.	Media Storage Conformance Statement	50
5.1.	Introduction	50
5.2.	Implementation Model	50
5.2.1.	Application Data Flow Diagram	50
5.2.2.	Functional Definition of AEs.....	50
5.2.3.	Sequencing of Real-World Activities	51
5.2.4.	File Meta Information for Implementation Class and Version	51
5.3.	AE Specifications.....	51
5.3.1.	Workstation AE Specification.....	51
5.3.2.	Real World Activities	52
5.4.	Augmented and Private Application Profiles.....	54
5.4.1.	Augmented Application Profiles	54
5.4.2.	Private Application Profiles.....	54
5.5.	Extensions, Specializations, Privatizations of SOP Classes, and Transfer Syntaxes	54
5.5.1.	Extensions, Specializations, and Privatizations of SOP Classes	54
5.5.2.	Private Transfer Syntax Specification.....	56
5.6.	Configuration	57
5.7.	Support of Extended Character Sets	57

Preface

The intent of any DICOM conformance statement is to provide a knowledgeable user with the information required in determining whether and to what extent independent DICOM implementations may be able to inter-operate. However, the information contained in a DICOM conformance statement is not sufficient to ensure if independent implementations will, in fact, be able to inter-operate.

The user or system integrator must be aware of the following potential issues related to inter-operation:

- Using only the information provided by this Conformance Statement does not guarantee interoperability of Merge equipment with non-Merge equipment. It is the user's (or system integrator's) responsibility to thoroughly analyze the application requirements and objectives to determine if they can be met by the connection of Merge equipment to non-Merge equipment.
- Merge equipment has been tested to assure that the actual implementation of the DICOM interface corresponds with this Conformance statement. It is the responsibility of the user (or system integrator) to specify and carry out additional validation testing, which covers a broad spectrum of potential interactions between the independent implementations.
- Merge reserves the right to make changes to its products or to discontinue their delivery. Therefore, the user (or system integrator) should ensure that any future versions of Merge or non-Merge equipment are regression tested to verify that new software releases have not adversely impacted the ability to inter-operate.

Merge provides this documentation "as is" without warranty of any kind, either expressed or implied, including, but not limited to, the implied warranties or merchantability and fitness for a particular purpose. Some states or countries do not allow disclaimers of express or implied warranties in certain transactions; therefore, this statement may not apply to you.

No part of this publication may be reproduced, transmitted, transcribed, recorded, or translated into any language in any form or by any means, electronic, magnetic, optical, chemical, physical or otherwise.

Merge reserves the right to correct this publication and to make changes to its contents without the obligation of informing anyone of these revisions or changes.

Operational Precautions

- Not for diagnostic use on a mobile device such as a smart phone or a tablet.
- U.S. federal law restricts this device to sale by, or on the order of, a physician.
- If a modality is incorrectly configured, Merge Cardio will be unaware and will display images as received. New or updated modalities should be tested to meet expected performance and functionality prior to use. If an unexpected distortion is observed when viewing images, ensure that the source modality is configured correctly.

Chapter 1. Introduction

This document specifies the conformance of the Merge Cardio 12.1 Workstation to the DICOM V3.0 standard.

DICOM service classes, information objects, and media application profiles supported by the Merge Cardio Workstation are detailed within this document.

1.1. Audience

The reader of this document is assumed familiar with the terminology and concepts described in the DICOM standard.

1.2. Terminology

The following terms are defined for the remainder of this document:

Term	Definition
CD / DVD	Refers to both stamped CD / DVD-ROM media and CD / DVD-R media. A CD / DVD-ROM drive can read both CD / DVD-ROM and CD / DVD-R media.
CD / DVD-R	Refers to 120mm recordable media as defined in Part II: CD / DVD-WO version 2.0 in the Orange Book.
FSC	A File-Set Creator
FSR	A File-Set Reader
GUI	A Graphical User Interface
SOP	A Service-Object Pair

1.3. Related Documents

- NEMA (2011) The DICOM Standard: Parts 1-20

Chapter 2. Network Conformance Statement

2.1. Introduction

This DICOM Conformance Statement covers the **Merge Cardio Workstation**.

The **Merge Cardio Workstation** provides a DICOM network connection to the modality systems as well as to other DICOM-compliant imaging systems. The **Merge Cardio Workstation** is both a review station and a DICOM-compliant CD / DVD reader and writer. DICOM-compliant CD / DVD media can be created for archive or for transfer to other institutions. DICOM-compliant CD / DVD media received from other institutions, including those produced by other manufacturers' equipment can be reviewed on each **Merge Cardio Workstation**. The **Merge Cardio Workstation** offers diagnostic image quality and processing capabilities as well as Quantitative Coronary Analysis and Left Ventricular Analysis packages, calipers and annotation.

Many features and functions are separately purchasable licensed options. Description of functions does not indicate that the user is entitled to these functions on any given system. Refer to sales quotations and purchase agreement for availability of options.

2.2. Implementation Model

2.2.1. Application Data Flow Diagram

As documented in the DICOM Standard Part 2, the arrows in the diagram on the following page have the following meanings:

- A double-headed arrow indicates user interaction with the local application entity.
- An arrow pointing to the right indicates the local application entity initiates an association.
- An arrow pointing to the left indicates the local application entity accepts an association.

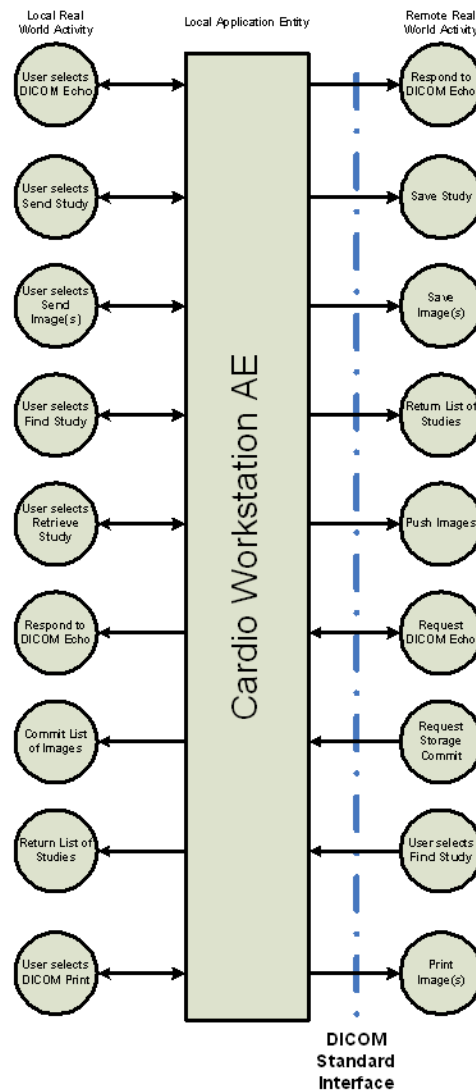

2.2.2. Functional Definition of Application Entities (AE)

The DICOM echo functionality enables the user to verify the DICOM network communication/protocol stack is properly working. An association is established with the remote DICOM AE and a C-Echo operation is carried out as specified by the DICOM Verification service class.

The send study functionality enables the user to send a copy of the set of images belonging to a study that resides on the local file system to a remote DICOM AE. A single association is established to send a copy of each image belonging to the study to the remote DICOM AE as specified by the DICOM Storage service class. This functionality also allows the sending of a single image or multiple images from a study without sending the entire study.

The find study functionality enables the user to find a particular study on a remote DICOM AE. The Merge Cardio Workstation forms a C-Find request that contains a set of search parameters as specified by the DICOM Query/Retrieve service class. The Merge Cardio Workstation receives each matching C-Find response corresponding to a study and displays the information to the user.

The retrieve study functionality enables the user to retrieve a study from a remote DICOM AE. The Merge Cardio Workstation forms a C-Move request as specified in the Query/Retrieve service class.

The retrieve AE title and study UID that is required in the C-Move request is determined based on information returned in a previous C-Find response.

The print functionality enables the user to send images to a DICOM compatible printing device for printing.

The Merge Cardio Workstation accepts an association with a remote DICOM AE when the remote system requests network communication verification using the DICOM Verification service class. A message is logged that specifies the source AE title of the verification request. No other local real-world activity occurs.

The Merge Cardio Workstation accepts an association with a remote DICOM AE when the remote system requests image storage using the DICOM Storage service class. The image is written to the local file system and added to the study database associated with the image. A message is logged pertaining to the new image added that specifies the remote AE title and file path.

The Merge Cardio Workstation accepts an association with a remote DICOM AE when the remote system requests a DICOM Query, using a C-Find request with a set of search parameters as specified by the DICOM Query/Retrieve service class. The Merge Cardio Workstation matches the parameters with the local studies and returns a C-Find response for each match.

The Merge Cardio Workstation accepts an association with a remote DICOM AE when the remote system wishes to retrieve study(s) received in the C-Find responses. The Merge Cardio Workstation establishes a new single association for each study being retrieved and sends a copy of each image belonging to the study to the DICOM AE specified in the C-Move request.

The Merge Cardio Workstation accepts an association with a remote DICOM AE when the remote system requests commitment of a list of images using the DICOM Storage Commit service class. The N-Action request is processed as specified by the Storage Commit Push Model of the service class. The N-Event response is sent over another association initiated by the Merge Cardio Workstation.

2.2.3. Sequencing of Real-World Activities

The user must query for a list of studies prior to retrieving a study.

2.3. Application Entity Specifications

2.3.1. Workstation DICOM AE Specification

The Merge Cardio Workstation provides standard conformance to the following DICOM SOP classes as a Service Class User (SCU):

Service Class	SOP Class Name	SOP Class UID
Verification	Verification	1.2.840.10008.1.1
Storage	X-Ray Angiographic Image Storage	1.2.840.10008.5.1.4.1.1.12.1
	Ultrasound Multi-Frame Image Storage	1.2.840.10008.5.1.4.1.1.3.1
	Ultrasound Multi-Frame Image Storage (Ret)	1.2.840.10008.5.1.4.1.1.3
	Ultrasound Image Storage	1.2.840.10008.5.1.4.1.1.6.1
	Ultrasound Image Storage (Ret)	1.2.840.10008.5.1.4.1.1.6
	Secondary Capture Image Storage	1.2.840.10008.5.1.4.1.1.7
	Multi-frame Grayscale Byte Secondary Capture Image Storage	1.2.840.10008.5.1.4.1.1.7.2
	Multi-frame Grayscale Word Secondary Capture Image Storage	1.2.840.10008.5.1.4.1.1.7.3
	Multi-frame Grayscale True Color Secondary Capture Image Storage	1.2.840.10008.5.1.4.1.1.7.4
	X-Ray Radiofluoroscopic (RF) Image Storage	1.2.840.10008.5.1.4.1.1.12.2
	Nuclear Medicine (NM) Image Storage	1.2.840.10008.5.1.4.1.1.20
	Computed Radiography (CR) Image Storage	1.2.840.10008.5.1.4.1.1.1
	CT Image Storage	1.2.840.10008.5.1.4.1.1.2
	MR Image Storage	1.2.840.10008.5.1.4.1.1.4
	Positron Emission Tomography (PET) Image Storage	1.2.840.10008.5.1.4.1.1.128
	Basic Text SR	1.2.840.10008.5.1.4.1.1.88.11
	Enhanced SR	1.2.840.10008.5.1.4.1.1.88.22
Comprehensive SR	1.2.840.10008.5.1.4.1.1.88.33	

Service Class	SOP Class Name	SOP Class UID
	Study Root Q/R Information Model - FIND	1.2.840.10008.5.1.4.1.2.2.1
	Digital Mammography (MG) Image Storage For Processing SOP Class	1.2.840.10008.5.1.4.1.1.1.2.1
	Digital Mammography (MG) Image Storage for Presentation SOP Class	1.2.840.10008.5.1.4.1.1.1.2
	Digital X-ray Image Storage for Presentation	1.2.840.10008.5.1.4.1.1.1.1
	Digital X-ray Image Storage for Processing	1.2.840.10008.5.1.4.1.1.1.1.1
Query/Retrieve	Study Root Q/R Information Model - MOVE	1.2.840.10008.5.1.4.1.2.2.2
	Basic Grayscale Print Management Meta SOP	1.2.840.10008.5.1.1.9
Print Management	Basic Color Print Management Meta SOP	1.2.840.10008.5.1.1.18

The Merge Cardio Workstation also provides standard conformance to the following DICOM SOP classes as a Service Class Provider (SCP):

Service Class	SOP Class Name	SOP Class UID
Verification	Verification	1.2.840.10008.1.1
Storage	X-Ray Angiographic Image Storage	1.2.840.10008.5.1.4.1.1.12.1
	Ultrasound Multi-Frame Image Storage	1.2.840.10008.5.1.4.1.1.3.1
	Ultrasound Multi-Frame Image Storage (Ret)	1.2.840.10008.5.1.4.1.1.3
	Ultrasound Image Storage	1.2.840.10008.5.1.4.1.1.6.1
	Ultrasound Image Storage (Ret)	1.2.840.10008.5.1.4.1.1.6
	Secondary Capture Image Storage	1.2.840.10008.5.1.4.1.1.7
	Multi-frame Grayscale Byte Secondary Capture Image Storage	1.2.840.10008.5.1.4.1.1.7.2
	Multi-frame Grayscale Word Secondary Capture Image Storage	1.2.840.10008.5.1.4.1.1.7.3
	Multi-frame Grayscale True Color Secondary Capture Image Storage	1.2.840.10008.5.1.4.1.1.7.4
	X-Ray Radiofluoroscopic (RF) Image Storage	1.2.840.10008.5.1.4.1.1.12.2
	Nuclear Medicine (NM) Image Storage	1.2.840.10008.5.1.4.1.1.20

Service Class	SOP Class Name	SOP Class UID
	Nuclear Medicine (NM) Image Storage (Retired)	1.2.840.10008.5.1.4.1.1.5
	Computed Radiography (CR) Image Storage	1.2.840.10008.5.1.4.1.1.1
	CT Image Storage	1.2.840.10008.5.1.4.1.1.2
	MR Image Storage	1.2.840.10008.5.1.4.1.1.4
	Positron Emission Tomography (PET) Image Storage	1.2.840.10008.5.1.4.1.1.128
	Digital Mammography (MG) Image Storage For Processing SOP Class	1.2.840.10008.5.1.4.1.1.1.2.1
	Digital Mammography (MG) Image Storage for Presentation SOP Class	1.2.840.10008.5.1.4.1.1.1.2
	Digital X-ray Image Storage for Presentation	1.2.840.10008.5.1.4.1.1.1.1
	Digital X-ray Image Storage for Processing	1.2.840.10008.5.1.4.1.1.1.1.1
	Basic Text SR	1.2.840.10008.5.1.4.1.1.88.11
	Enhanced SR	1.2.840.10008.5.1.4.1.1.88.22
	Comprehensive SR	1.2.840.10008.5.1.4.1.1.88.33
Query/Retrieve	Study Root Q/R Information Model - FIND	1.2.840.10008.5.1.4.1.2.2.1
	Study Root Q/R Information Model - MOVE	1.2.840.10008.5.1.4.1.2.2.2
Storage Commit	Storage Commit Push Model	1.2.840.10008.1.20.1

2.4. Association Initiation Policies

2.4.1. General

The Merge Cardio Workstation always proposes the following DICOM Application Context Name (ACN):

Application Context Name

1.2.840.10008.3.1.1.1

The maximum length PDU negotiation is included in all association establishment requests. The default maximum length PDU for an association initiated by the Merge Cardio Workstation is:

Maximum Length PDU

1,048,576 bytes

a. Number of Associations

The default number of associations that may be active simultaneously is 20.

b. Asynchronous Nature

DICOM asynchronous mode is not supported meaning that only one transaction may be outstanding over an association at any given point in time.

c. Implementation Identifying Information

The implementation class UID for the Merge Cardio Workstation is the following:

Implementation Class UID

1.2.840.113697.6.8

The implementation version name has the following syntax. It is limited to 16 characters.

Implementation Version Name

<major revision>.<minor revision>.<validation cycle>.<verification cycle>

2.4.2. Association Initiation Policy

The Merge Cardio Workstation AE establishes an association for the following user requests.

- Verification (C-Echo) request to remote DICOM AE
- Send study to remote DICOM AE
- Find a study on a remote DICOM AE database
- Retrieve a study from a remote DICOM AE
- Send image(s) to remote DICOM printer AE
- Send image(s) to remote DICOM printer AE

2.4.3. Real-World Activity “User Selects DICOM Echo”

a. Associated Real-World Activity

A user who is a member of the Merge service group selects the DICOM Network preferences tab. The user may then select a remote DICOM application entity and press the “DICOM Echo” button. An association will be initiated with the selected remote DICOM application entity. Upon successful association establishment, the C-Echo request/response operation occurs over the association.

b. Proposed Presentation Contexts

The following table illustrates the proposed presentation context for the DICOM Verification request.

Abstract Syntax		Transfer Syntax		Role	Extended Negotiation
Name	UID	Name	UID		
Verification	1.2.840.10008.1.1	Implicit VR Little Endian	1.2.840.10008.1.2	SCU	None

c. SOP-Specific Conformance

An appropriate error message is logged if the C-Echo request/response operation fails for any reason. The operator is notified of the success or failure of the DICOM Echo request.

d. Association Termination

The Merge Cardio Workstation will release the association when the C-Echo Response from the remote DICOM AE is received.

e. Real-World Activity “User Selects Send Study/Image”

f. Associated Real-World Activity

The user selects a study from the main study list view or thumbnail images on the study list view or the patient info view, and presses the Send Study icon. The context menu on the mouse (right-click) can also be used. A list of remote DICOM AEs that support the storage service class is presented to the user. The user selects a remote DICOM AE and presses the Send Study button to queue the request. An association will be initiated with the selected remote DICOM AE. Upon successful association establishment, the C-Store request/response operation will occur for each image that belongs to the study at the time the association was initiated.

The Merge Cardio Workstation can also be configured to “Auto Forward” images. These images are received from other DICOM AEs and are auto forwarded to DICOM AEs that are configured as Auto Forward destinations without user intervention.

The user has the ability to edit patient/study level demographics. All images belonging to the study will be sent with the same patient/study level demographics.

Progress information is displayed to the user in the send queue dialog that displays the number of pending, failed, and successful C-Store operations.

If required, the Merge Cardio Workstation will perform the following transfer syntax conversion operation.

Original Transfer Syntax UID	Destination Transfer Syntax UID
JPEG Lossless Process 14 1.2.840.10008.1.2.4.70	Explicit VR Little Endian 1.2.840.10008.1.2.1
JPEG Lossless Process 14 1.2.840.10008.1.2.4.70	Implicit VR Little Endian 1.2.840.10008.1.2

2.4.4. Proposed Presentation Contexts

The following table illustrates the proposed presentation context for the association used to implement the Send Study user request.

Presentation Context Table – Proposed					
Abstract Syntax		Transfer Syntax		Role	Extended Negotiation
Name	UID	Name	UID		
Verification	1.2.840.10008.1.1	Implicit VR Little Endian	1.2.840.10008.1.2	SCU	None
X-Ray Angio-graphic Image Storage	1.2.840.10008.5.1.4.1.1.12.1	Implicit VR Little Endian	1.2.840.10008.1.2	SCU	None
X-Ray Angio-graphic Image Storage	1.2.840.10008.5.1.4.1.1.12.1	Explicit VR Little Endian	1.2.840.10008.1.2.1	SCU	None
X-Ray Angio-graphic Image Storage	1.2.840.10008.5.1.4.1.1.12.1	JPEG Lossless Process 14 (Selection Value 1)	1.2.840.10008.1.2.4.70	SCU	None
US Multi-frame Image Storage	1.2.840.10008.5.1.4.1.1.3.1	JPEG Lossy Process 1	1.2.840.10008.1.2.4.50	SCU	None
US Multi-frame Image Storage (Retired)	1.2.840.10008.5.1.4.1.1.3	JPEG Lossy Process 1	1.2.840.10008.1.2.4.50	SCU	None
Secondary Capture Image Storage	1.2.840.10008.5.1.4.1.1.7	Implicit VR Little Endian	1.2.840.10008.1.2	SCU	None
Secondary Capture Image Storage	1.2.840.10008.5.1.4.1.1.7	Explicit VR Little Endian	1.2.840.10008.1.2.1	SCU	None
Secondary Capture Image Storage	1.2.840.10008.5.1.4.1.1.7	Explicit VR Big Endian	1.2.840.10008.1.2.2	SCU	None

Presentation Context Table – Proposed					
Abstract Syntax		Transfer Syntax		Role	Extended Negotiation
Name	UID	Name	UID		
Multi-frame Grayscale Byte Secondary Capture Image Storage	1.2.840.10008.5.1.4.1.1.7.2	Implicit VR Little Endian	1.2.840.10008.1.2	SCU	None
Multi-frame Grayscale Byte Secondary Capture Image Storage	1.2.840.10008.5.1.4.1.1.7.2	Explicit VR Little Endian	1.2.840.10008.1.2.1	SCU	None
Multi-frame Grayscale Byte Secondary Capture Image Storage	1.2.840.10008.5.1.4.1.1.7.2	JPEG Lossy Process 1	1.2.840.10008.1.2.4.50	SCU	None
Multi-frame Grayscale Byte Secondary Capture Image Storage	1.2.840.10008.5.1.4.1.1.7.2	JPEG Lossless Process 14 (Selection Value 1)	1.2.840.10008.1.2.4.70	SCU	None
Multi-frame Grayscale Byte Secondary Capture Image Storage	1.2.840.10008.5.1.4.1.1.7.2	Lossless, non-hierarchical	1.2.840.10008.1.2.4.57	SCU	None
Multi-frame Grayscale Byte Secondary Capture Image Storage	1.2.840.10008.5.1.4.1.1.7.2	RLE Lossless	1.2.840.10008.1.2.5	SCU	None
Multi-frame Grayscale Word Secondary Capture Image Storage	1.2.840.10008.5.1.4.1.1.7.3	Implicit VR Little Endian	1.2.840.10008.1.2	SCU	None

Presentation Context Table – Proposed					
Abstract Syntax		Transfer Syntax		Role	Extended Negotiation
Name	UID	Name	UID		
Multi-frame Grayscale Word Secondary Capture Image Storage	1.2.840.10008.5.1.4.1.1.7.3	Explicit VR Little Endian	1.2.840.10008.1.2.1	SCU	None
Multi-frame Grayscale Word Secondary Capture Image Storage	1.2.840.10008.5.1.4.1.1.7.3	JPEG Lossy Process 1	1.2.840.10008.1.2.4.50	SCU	None
Multi-frame Grayscale Word Secondary Capture Image Storage	1.2.840.10008.5.1.4.1.1.7.3	JPEG Lossless Process 14 (Selection Value 1)	1.2.840.10008.1.2.4.70	SCU	None
Multi-frame Grayscale Word Secondary Capture Image Storage	1.2.840.10008.5.1.4.1.1.7.3	Lossless, non-hierarchical	1.2.840.10008.1.2.4.57	SCU	None
Multi-frame Grayscale Word Secondary Capture Image Storage	1.2.840.10008.5.1.4.1.1.7.3	RLE Lossless	1.2.840.10008.1.2.5	SCU	None
Multi-frame Grayscale True Color Secondary Capture Image Storage	1.2.840.10008.5.1.4.1.1.7.4	Implicit VR Little Endian	1.2.840.10008.1.2	SCU	None
Multi-frame Grayscale True Color Secondary Capture Image Storage	1.2.840.10008.5.1.4.1.1.7.4	Explicit VR Little Endian	1.2.840.10008.1.2.1	SCU	None

Presentation Context Table – Proposed					
Abstract Syntax		Transfer Syntax		Role	Extended Negotiation
Name	UID	Name	UID		
Multi-frame Grayscale True Color Secondary Capture Image Storage	1.2.840.10008.5.1.4.1.1.7.4	JPEG Lossy Process 1	1.2.840.10008.1.2.4.50	SCU	None
Multi-frame Grayscale True Color Secondary Capture Image Storage	1.2.840.10008.5.1.4.1.1.7.4	JPEG Lossless Process 14 (Selection Value 1)	1.2.840.10008.1.2.4.70	SCU	None
Multi-frame Grayscale True Color Secondary Capture Image Storage	1.2.840.10008.5.1.4.1.1.7.4	Lossless, non-hierarchical	1.2.840.10008.1.2.4.57	SCU	None
Multi-frame Grayscale True Color Secondary Capture Image Storage	1.2.840.10008.5.1.4.1.1.7.4	RLE Lossless	1.2.840.10008.1.2.5	SCU	None
X-Ray Radiofluoroscopic (RF) Image Storage	1.2.840.10008.5.1.4.1.1.12.2	Implicit VR Little Endian	1.2.840.10008.1.2	SCU	None
X-Ray Radiofluoroscopic (RF) Image Storage	1.2.840.10008.5.1.4.1.1.12.2	Explicit VR Little Endian	1.2.840.10008.1.2.1	SCU	None
X-Ray Radiofluoroscopic (RF) Image Storage	1.2.840.10008.5.1.4.1.1.12.2	JPEG Lossy Process 1	1.2.840.10008.1.2.4.50	SCU	None

Presentation Context Table – Proposed					
Abstract Syntax		Transfer Syntax		Role	Extended Negotiation
Name	UID	Name	UID		
Computed Radiography (CR) Image Storage	1.2.840.10008.5.1.4.1.1.1	Implicit VR Little Endian	1.2.840.10008.1.2	SCU	None
Computed Radiography (CR) Image Storage	1.2.840.10008.5.1.4.1.1.1	Explicit VR Little Endian	1.2.840.10008.1.2.1	SCU	None
CT Image Storage	1.2.840.10008.5.1.4.1.1.2	Implicit VR Little Endian	1.2.840.10008.1.2	SCU	None
CT Image Storage	1.2.840.10008.5.1.4.1.1.2	Explicit VR Little Endian	1.2.840.10008.1.2.1	SCU	None
Nuclear Medicine (NM) Image Storage	1.2.840.10008.5.1.4.1.1.20	Implicit VR Little Endian	1.2.840.10008.1.2	SCU	None
Nuclear Medicine (NM) Image Storage	1.2.840.10008.5.1.4.1.1.20	Explicit VR Little Endian	1.2.840.10008.1.2.1	SCU	None
Nuclear Medicine (NM) Image Storage (Retired)	1.2.840.10008.5.1.4.1.1.5	Implicit VR Little Endian	1.2.840.10008.1.2	SCU	None
Nuclear Medicine (NM) Image Storage (Retired)	1.2.840.10008.5.1.4.1.1.5	Explicit VR Little Endian	1.2.840.10008.1.2.1	SCU	None
MR Image Storage	1.2.840.10008.5.1.4.1.1.4	Implicit VR Little Endian	1.2.840.10008.1.2	SCU	None
MR Image Storage	1.2.840.10008.5.1.4.1.1.4	Explicit VR Little Endian	1.2.840.10008.1.2.1	SCU	None
Positron Emission Tomography (PET) Image Storage	1.2.840.10008.5.1.4.1.1.128	Implicit VR Little Endian	1.2.840.10008.1.2	SCU	None

Presentation Context Table – Proposed					
Abstract Syntax		Transfer Syntax		Role	Extended Negotiation
Name	UID	Name	UID		
Positron Emission Tomography (PET) Image Storage	1.2.840.10008.5.1.4.1.1.1.28	Explicit VR Little Endian	1.2.840.10008.1.2.1	SCU	None
Digital Mammography (MG) Image Storage For Processing SOP Class	1.2.840.10008.5.1.4.1.1.1.2.1	Implicit VR Little Endian	1.2.840.10008.1.2	SCU	None
Digital Mammography (MG) Image Storage For Processing SOP Class	1.2.840.10008.5.1.4.1.1.1.2.1	Explicit VR Little Endian	1.2.840.10008.1.2.1	SCU	None
Digital Mammography (MG) Image Storage for Presentation SOP Class	1.2.840.10008.5.1.4.1.1.1.2	Implicit VR Little Endian	1.2.840.10008.1.2	SCU	None
Digital Mammography (MG) Image Storage for Presentation SOP Class	1.2.840.10008.5.1.4.1.1.1.2	Explicit VR Little Endian	1.2.840.10008.1.2.1	SCU	None
Digital X-ray Image Storage for Presentation	1.2.840.10008.5.1.4.1.1.1.1	Implicit VR Little Endian	1.2.840.10008.1.2	SCU	None
Digital X-ray Image Storage for Presentation	1.2.840.10008.5.1.4.1.1.1.1	Explicit VR Little Endian	1.2.840.10008.1.2.1	SCU	None
Digital X-ray Image Storage for Processing	1.2.840.10008.5.1.4.1.1.1.1.1	Implicit VR Little Endian	1.2.840.10008.1.2	SCU	None

Presentation Context Table – Proposed					
Abstract Syntax		Transfer Syntax		Role	Extended Negotiation
Name	UID	Name	UID		
Digital X-ray Image Storage for Processing	1.2.840.10008.5.1.4.1.1.1.1.1	Explicit VR Little Endian	1.2.840.10008.1.2.1	SCU	None

Selection of a transfer syntax for either abstract syntax is as follows (in this order):

Determine if the accepted context table has a transfer syntax that matches the native transfer syntax of the image. If yes, use that to send the image(s)/report (s).

Determine if the accepted context table has a transfer syntax of Explicit VR Little Endian. If yes, use that to send the image(s) /report (s).

Determine if the accepted context table has a transfer syntax of Implicit VR Little Endian. If yes, use that to send the image(s) /report (s).

Abort the association and log an error message.

a. SOP-Specific Conformance

An appropriate error message is logged when a C-Store request/response operation fails for any reason. The operator is notified if the Send Study request fails for any reason.

A message containing the command response value returned from the C-Store SCP is logged for all image transfers.

The user is informed in the send queue dialog of the number of successfully completed and failed image transfers. The following command response status codes are considered warnings and are represented to the user as successfully completed image transfers. All other non-zero command response status values are represented to the user as a failed image transfer.

Status Code	Description
0xB000	Data Element Coercion Warning
0xB006	Element Discarded
0xB007	SOP Class Mismatch
0xC111	Duplicate Image

All other non-zero response status values are represented to the user as a failed image transfer.

b. Association Termination

The Merge Cardio Workstation will release the association when all images in the study have been sent to the remote DICOM AE. The association will be abnormally terminated if any error is encountered or the user cancels the Send Study request from the Send Queue dialog.

c. Real-World Activity “User Selects Find Study”

d. Associated Real-World Activity

The Merge Cardio Workstation will initiate an association when the user presses the Find Study button from the Find Study dialog. Upon successful association establishment, a C-Find request is formed based on selection criteria entered by the user. Each C-Find response is displayed to the user as one line on the list of studies found.

e. Proposed Presentation Contexts

The following table illustrates the proposed presentation context for the Find Study user request.

Abstract Syntax		Transfer Syntax		Role	Extended Negotiation
Name	UID	Name	UID		
Study Root Query Retrieve Information Model (C-Find)	1.2.840.10008.5.1.4.1.2.2.1	Implicit VR Little Endian	1.2.840.10008.1.2	SCU	None

f. SOP-Specific Conformance

An appropriate error message is logged if the C-Find request/response operation fails for any reason. The operator is notified of the success or failure DICOM C-Find request.

The Query/Retrieve Level (0008,0052) always has a value of “STUDY”.

The relational query option is not supported.

The C-Find request for the Study Root Query Retrieve information model is composed of the following required and optional keys.

Tag	Attribute Name	VR	VM	Req	Notes
(0008,0005)	Specific Character Set	CS	1	O	value returned only
(0008,0020)	Study Date	DA	1	R	user may enter start and/or end date
(0008,0030)	Study Time	TM	1	R	value returned only
(0008,0050)	Accession Number	SH	1	R	user may specify
(0008,0052)	Query Level	CS	1	R	Value = “STUDY”
(0008,0054)	Retrieve AE Title	AE	1	O	value returned only
(0008,0061)	Modalities in Study	CS	1	O	Value = “XA”
(0008,0090)	Referring Physician	PN	1	O	user may specify
(0008,1030)	Study Description	LO	1	O	value returned only
(0008,1048)	Physician(s) of Record	PN	1-n	O	value returned only

Tag	Attribute Name	VR	VM	Req	Notes
(0008,1050)	Performing Physician's Name	PN	1	O	user may specify
(0010,0010)	Patient Name	PN	1	R	user may specify
(0010,0020)	Patient ID	LO	1	R	user may specify
(0010,0021)	Issuer of Patient ID	LO	1	O	based on user
(0010,0030)	Patient DOB	DA	1	O	value returned only
(0010,0040)	Patient Sex	CS	1	O	value returned only
(0020,000D)	Study Instance UID	UI	1	U	value returned only
(0020,0010)	Study ID	SH	1	R	user may specify
(0020,1208)	Number of Study Related Images	IS	1	O	value returned only
(0032,000A)	Study Status ID	CS	1	O	value returned only
(0088,0130)	Storage Media File-Set ID	SH	1	O	value returned only
(0088,0140)	Storage Media File-Set UID	UI	1	O	value returned only

g. Association Termination

The Merge Cardio Workstation will release the association when the final C-Find Response is received over the association. The association will be abnormally terminated if any error is encountered or the user cancels the Find Study request.

h. Real-World Activity “User Selects Retrieve Study”

i. Associated Real-World Activity

The user selects a study from the list of studies returned from the previous find study user request and then presses the Retrieve button to queue the retrieval request. The study selected for retrieval is associated with a previous C-Find response, which contains a Retrieve AE title and Study UID. An association will be initiated with the Retrieve AE title associated with the user-selected study. Upon successful association establishment, a C-Move request is formed which contains the study UID corresponding to the user selected study.

Progress information is displayed to the user in the retrieve queue dialog based on C-Move pending and final responses received from the remote Retrieval AE.

j. Proposed Presentation Contexts

The following table illustrates the proposed presentation context for the Retrieve Study user request.

Abstract Syntax		Transfer Syntax		Role	Extended
Name	UID	Name	UID		Negotiation
Study Root Query Retrieve Information Model - MOVE	1.2.840.10008.5.1.4.1.2.2.2	Implicit VR Little Endian	1.2.840.10008.1.2	SCU	None

k. SOP-Specific Conformance

An appropriate error message is logged if the C-Move request/response operation fails for any reason. The operator is notified if the Move request fails for any reason. The following response status codes are considered errors:

Status Code	Description
A701	Out of resources – Unable to calculate number of matches
A702	Out of resources – Unable to perform suboperations
A801	Move Destination unknown
A900	Identifier does not match SOP Class
C000	Unable to process

The Query/Retrieve Level (0008,0052) always has a value of “STUDY”.

l. Association Termination

The Merge Cardio Workstation will release the association when the final C-Move Response from the remote DICOM Retrieve AE is received. A C-Cancel request is sent over the association if the user cancels the Retrieve Study request from the Retrieve Queue dialog.

m. Real-World Activity “User Submits Print Job”

n. Associated Real-World Activity

When a user selects image from the study currently being reviewed and selects the “DICOM Print” item from the menu, the image will be queued for printing. Depending upon the printer configuration (images per sheet of film), the request may be immediately processed or may wait for subsequent image(s) to be requested and added to the current film sheet

Every print job will initiate an association. The order in which the transaction will be made is as follows:

Association Negotiation

N-GET of Printer SOP Instance to determine printer status

```

N-CREATE of Film Session SOP Instance for each image in the film box
For each film box in the job
{
N-CREATE of Film Box SOP Instance
For each image in the film box
{
N-SET of Image Box SOP Instance
}
N-ACTION of Film Box SOP Instance
N-DELETE of Film Box SOP Instance
}
Release Association

```

Progress information is displayed to the user in the print queue dialog based on N-SET responses received from the remote printer AE.

o. Proposed Presentation Contexts

The following table illustrates the proposed presentation context for the DICOM Print user request.

Presentation Context Table – Proposed					
Abstract Syntax		Transfer Syntax		Role	Extended Negotiation
Name	UID	Name	UID		
Basic Gray-scale Print Management Meta SOP	1.2.840.10008.5.1.1.9	Implicit VR Little Endian	1.2.840.10008.1.2	SCU	None
Basic Color Print Management Meta SOP	1.2.840.10008.5.1.1.18	Implicit VR Little Endian	1.2.840.10008.1.2	SCU	None

p. SOP-Specific Conformance – Basic Print Management

The Merge Cardio Workstation AE provides standard conformance to the following Meta SOP Classes as an SCU:

SOP Class Name	SOP CLASS UID
Basic Grayscale Print Management	1.2.840.10008.5.1.1.9
Basic Color Print Management	1.2.840.10008.5.1.1.18

This corresponds to conformance to the following SOP classes as an SCU:

q. SOP Class Conformance as an SCU

SOP Class Name	SOP CLASS UID
Basic Film Session	1.2.840.10008.5.1.1.1
Basic Film Box	1.2.840.10008.5.1.1.2
Basic Grayscale Image Box	1.2.840.10008.5.1.1.4
Basic Color Image Box	1.2.840.10008.5.1.1.4.1

For attributes supported by the review station, refer to [SECTION 4.1.1. BELOW](#), [SECTION 4.1.2. BELOW](#), and [SECTION 4.1.3. BELOW](#).

An appropriate error message is logged when an N-GET, N-Create, N-SET, N-ACTION or N-DELETE request/response operation fails for any reason.

A message containing the response value returned from the printer is logged for all N-Service messages.

The user is informed in the print queue dialog of the success or failure of the print request.

r. Association Termination

The review station will release the association when N-DELETE Response is received from the remote DICOM printer AE. A C-Cancel request is sent over the association if the user cancels the print request from the Print Queue dialog.

s. Number of Associations

At most one association will be active at a time.

2.4.5. Association Acceptance Policy

A new thread is created for each accepted transport connection. The new thread lives for the life of the association over the transport connection.

Hence, the Merge Cardio Workstation is able to process the following types of incoming DICOM requests simultaneously:

- Request for Verification (C-Echo)
- Request for Image Storage (C-Store)
- Request for Storage Commitment
- Request for Query (C-Find)

a. Real World Activity “Verification Server”

b. Associated Real-World Activity

The Merge Cardio Workstation is always ready to accept a new transport connection and create a thread to process the Verification request. The presentation context corresponding with the Verification request is accepted and a C-Echo response is sent over the established association.

c. Accepted Presentation Contexts

The following table illustrates the accepted presentation context for the DICOM Verification request.

Abstract Syntax		Transfer Syntax		Role	Extended Negotiation
Name	UID	Name	UID		
Verification	1.2.840.10008.1.1	Implicit VR Little Endian	1.2.840.10008.1.2	SCP	None

d. SOP-Specific Conformance

The Merge Cardio Workstation provides standard conformance to the DICOM verification service class.

e. Presentation Context Acceptance Criterion

Not Applicable.

f. Transfer Syntax Selection Policies

Not Applicable.

g. Real World Activity “Image Storage Server”

h. Associated Real-World Activity

When a remote AE sends a C-Store request, the Merge Cardio Workstation accepts the new transport connection and processes the Storage request. Multiple requests from different remote AEs can be accepted simultaneously. The Merge Cardio Workstation accepts the presentation context associated with each Image Storage request and replies with a C-Store response when the complete image has been received on the established association.

i. Accepted Presentation Contexts

The following table illustrates the accepted presentation contexts for the Image Storage request.

Presentation Context Table – Accepted					
Abstract Syntax		Transfer Syntax		Role	Extended Negotiation
Name	UID	Name	UID		
Verification	1.2.840.10008.1.1	Implicit VR Little Endian	1.2.840.10008.1.2	SCP	None

Presentation Context Table – Accepted					
Abstract Syntax		Transfer Syntax		Role	Extended Negotiation
Name	UID	Name	UID		
X-Ray Angio-graphic Image Storage	1.2.840.10008.5.1.4.1.1.12.1	Implicit VR Little Endian	1.2.840.10008.1.2	SCP	None
		JPEG Lossless Process 14 (Selection Value 1)	1.2.840.10008.1.2.4.70	SCP	None
		Explicit VR Little Endian	1.2.840.10008.1.2.1	SCP	None
		Explicit VR Big Endian	1.2.840.10008.1.2.2	SCP	None
US Multi-frame Image Storage	1.2.840.10008.5.1.4.1.1.3.1	JPEG Lossy Process 1	1.2.840.10008.1.2.4.50	SCP	None
		Explicit VR Little Endian	1.2.840.10008.1.2.1	SCP	None
		Implicit VR Little Endian	1.2.840.10008.1.2	SCP	None
US Multi-frame Image Storage (Ret)	1.2.840.10008.5.1.4.1.1.3	JPEG Lossy Process 1	1.2.840.10008.1.2.4.50	SCP	None
		Explicit VR Little Endian	1.2.840.10008.1.2.1	SCP	None
		Implicit VR Little Endian	1.2.840.10008.1.2	SCP	None
US Image Storage	1.2.840.10008.5.1.4.1.1.6.1	JPEG Lossy Process 1	1.2.840.10008.1.2.4.50	SCP	None
		Explicit VR Little Endian	1.2.840.10008.1.2.1	SCP	None
		Implicit VR Little Endian	1.2.840.10008.1.2	SCP	None
US Image Storage (Ret)	1.2.840.10008.5.1.4.1.1.6	JPEG Lossy Process 1	1.2.840.10008.1.2.4.50	SCP	None
		Explicit VR Little Endian	1.2.840.10008.1.2.1	SCP	None
		Implicit VR Little Endian	1.2.840.10008.1.2	SCP	None

Presentation Context Table – Accepted					
Abstract Syntax		Transfer Syntax		Role	Extended Negotiation
Name	UID	Name	UID		
Secondary Capture Image Storage	1.2.840.10008.5.1.4.1.1.7	Implicit VR Little Endian	1.2.840.10008.1.2	SCP	None
		Explicit VR Little Endian	1.2.840.10008.1.2.1	SCP	None
		Explicit VR Big Endian	1.2.840.10008.1.2.2	SCP	None
Multi-frame Grayscale Byte Secondary Capture Image Storage	1.2.840.10008.5.1.4.1.1.7.2	Implicit VR Little Endian	1.2.840.10008.1.2	SCP	None
Multi-frame Grayscale Byte Secondary Capture Image Storage	1.2.840.10008.5.1.4.1.1.7.2	Explicit VR Little Endian	1.2.840.10008.1.2.1	SCP	None
Multi-frame Grayscale Byte Secondary Capture Image Storage	1.2.840.10008.5.1.4.1.1.7.2	JPEG Lossy Process 1	1.2.840.10008.1.2.4.50	SCP	None
Multi-frame Grayscale Byte Secondary Capture Image Storage	1.2.840.10008.5.1.4.1.1.7.2	JPEG Lossless Process 14 (Selection Value 1)	1.2.840.10008.1.2.4.70	SCP	None
Multi-frame Grayscale Byte Secondary Capture Image Storage	1.2.840.10008.5.1.4.1.1.7.2	Lossless, non-hierarchical	1.2.840.10008.1.2.4.57	SCP	None
Multi-frame Grayscale Byte Secondary Capture Image Storage	1.2.840.10008.5.1.4.1.1.7.2	RLE Lossless	1.2.840.10008.1.2.5	SCP	None

Presentation Context Table – Accepted					
Abstract Syntax		Transfer Syntax		Role	Extended Negotiation
Name	UID	Name	UID		
Multi-frame Grayscale Word Secondary Capture Image Storage	1.2.840.10008.5.1.4.1.1.7.3	Implicit VR Little Endian	1.2.840.10008.1.2	SCP	None
Multi-frame Grayscale Word Secondary Capture Image Storage	1.2.840.10008.5.1.4.1.1.7.3	Explicit VR Little Endian	1.2.840.10008.1.2.1	SCP	None
Multi-frame Grayscale Word Secondary Capture Image Storage	1.2.840.10008.5.1.4.1.1.7.3	JPEG Lossy Process 1	1.2.840.10008.1.2.4.50	SCP	None
Multi-frame Grayscale Word Secondary Capture Image Storage	1.2.840.10008.5.1.4.1.1.7.3	JPEG Lossless Process 14 (Selection Value 1)	1.2.840.10008.1.2.4.70	SCP	None
Multi-frame Grayscale Word Secondary Capture Image Storage	1.2.840.10008.5.1.4.1.1.7.3	Lossless, non-hierarchical	1.2.840.10008.1.2.4.57	SCP	None
Multi-frame Grayscale Word Secondary Capture Image Storage	1.2.840.10008.5.1.4.1.1.7.3	RLE Lossless	1.2.840.10008.1.2.5	SCP	None
Multi-frame Grayscale True Color Secondary Capture Image Storage	1.2.840.10008.5.1.4.1.1.7.4	Implicit VR Little Endian	1.2.840.10008.1.2	SCP	None

Presentation Context Table – Accepted					
Abstract Syntax		Transfer Syntax		Role	Extended Negotiation
Name	UID	Name	UID		
Multi-frame Grayscale True Color Secondary Capture Image Storage	1.2.840.10008.5.1.4.1.1.7.4	Explicit VR Little Endian	1.2.840.10008.1.2.1	SCP	None
Multi-frame Grayscale True Color Secondary Capture Image Storage	1.2.840.10008.5.1.4.1.1.7.4	JPEG Lossy Process 1	1.2.840.10008.1.2.4.50	SCP	None
Multi-frame Grayscale True Color Secondary Capture Image Storage	1.2.840.10008.5.1.4.1.1.7.4	JPEG Lossless Process 14 (Selection Value 1)	1.2.840.10008.1.2.4.70	SCP	None
Multi-frame Grayscale True Color Secondary Capture Image Storage	1.2.840.10008.5.1.4.1.1.7.4	Lossless, non-hierarchical	1.2.840.10008.1.2.4.57	SCP	None
Multi-frame Grayscale True Color Secondary Capture Image Storage	1.2.840.10008.5.1.4.1.1.7.4	RLE Lossless	1.2.840.10008.1.2.5	SCP	None
Computed Radiography (CR) Image Storage	1.2.840.10008.5.1.4.1.1.1	Implicit VR Little Endian	1.2.840.10008.1.2.1	SCP	None
Computed Radiography (CR) Image Storage	1.2.840.10008.5.1.4.1.1.1	Explicit VR Little Endian	1.2.840.10008.1.2.1	SCP	None
CT Image Storage	1.2.840.10008.5.1.4.1.1.1	Implicit VR Little Endian	1.2.840.10008.1.2.2	SCP	None

Presentation Context Table – Accepted						
Abstract Syntax		Transfer Syntax		Role	Extended Negotiation	
Name	UID	Name	UID			
CT Image Storage	1.2.840.10008.5.1.4.1.1.2	Explicit VR Little Endian	1.2.840.10008.1.2.1	SCP	None	
Nuclear Medicine (NM) Image Storage	1.2.840.10008.5.1.4.1.1.20	Implicit VR Little Endian	1.2.840.10008.1.2	SCP	None	
Nuclear Medicine (NM) Image Storage	1.2.840.10008.5.1.4.1.1.20	Explicit VR Little Endian	1.2.840.10008.1.2.1	SCP	None	
Nuclear Medicine (NM) Image Storage (Retired)	1.2.840.10008.5.1.4.1.1.5	Implicit VR Little Endian	1.2.840.10008.1.2	SCP	None	
Nuclear Medicine (NM) Image Storage (Retired)	1.2.840.10008.5.1.4.1.1.5	Explicit VR Little Endian	1.2.840.10008.1.2.1	SCP	None	
MR Image Storage	1.2.840.10008.5.1.4.1.1.4	Implicit VR Little Endian	1.2.840.10008.1.2	SCP	None	
MR Image Storage	1.2.840.10008.5.1.4.1.1.4	Explicit VR Little Endian	1.2.840.10008.1.2.1	SCP	None	
Positron Emission Tomography (PET) Image Storage	1.2.840.10008.5.1.4.1.1.128	Implicit VR Little Endian	1.2.840.10008.1.2	SCP	None	
Positron Emission Tomography (PET) Image Storage	1.2.840.10008.5.1.4.1.1.128	Explicit VR Little Endian	1.2.840.10008.1.2.1	SCP	None	
X-Ray Radiofluoroscopic (RF) Image Storage	1.2.840.10008.5.1.4.1.1.12.2	Implicit VR Little Endian	1.2.840.10008.1.2	SCP	None	

Presentation Context Table – Accepted						
Abstract Syntax		Transfer Syntax		Role	Extended Negotiation	
Name	UID	Name	UID			
X-Ray Radiofluoroscopic (RF) Image Storage	1.2.840.10008.5.1.4.1.1.12.2	Explicit VR Little Endian	1.2.840.10008.1.2.1	SCP	None	
Basic Text SR	1.2.840.10008.5.1.4.1.1.88.11	Implicit VR Little Endian	1.2.840.10008.1.2	SCP	None	
Basic Text SR	1.2.840.10008.5.1.4.1.1.88.11	Explicit VR Little Endian	1.2.840.10008.1.2.1	SCP	None	
Enhanced SR	1.2.840.10008.5.1.4.1.1.88.22	Implicit VR Little Endian	1.2.840.10008.1.2	SCP	None	
Enhanced SR	1.2.840.10008.5.1.4.1.1.88.22	Explicit VR Little Endian	1.2.840.10008.1.2.1	SCP	None	
Comprehensive SR	1.2.840.10008.5.1.4.1.1.88.33	Implicit VR Little Endian	1.2.840.10008.1.2	SCP	None	
Comprehensive SR	1.2.840.10008.5.1.4.1.1.88.33	Explicit VR Little Endian	1.2.840.10008.1.2.1	SCP	None	
Digital Mammography (MG) Image Storage For Processing SOP Class	1.2.840.10008.5.1.4.1.1.1.2.1	Explicit VR Little Endian	1.2.840.10008.1.2.1	SCU	None	
Digital Mammography (MG) Image Storage for Presentation SOP Class	1.2.840.10008.5.1.4.1.1.1.2	Implicit VR Little Endian	1.2.840.10008.1.2	SCU	None	
Digital X-ray Image Storage for Presentation	1.2.840.10008.5.1.4.1.1.1.1	Implicit VR Little Endian	1.2.840.10008.1.2	SCU	None	
Digital X-ray Image Storage for Processing	1.2.840.10008.5.1.4.1.1.1.1.1	Implicit VR Little Endian	1.2.840.10008.1.2	SCU	None	

j. SOP-Specific Conformance

The Merge Cardio Workstation conforms to the SOP's of the Storage Service Class at level 2 (full). No data elements are discarded or coerced by the Merge Cardio Workstation.

Demographics for the first image received are represented to the user as demographics for the entire study. Demographics for subsequent images received for a study are ignored. The user has the ability to edit patient/study level demographics.

The following status codes indicate the Merge Cardio Workstation was unable to locally install the object.

Status Code	Description
0xA700	Insufficient free space is available to install the image.
0xA701	Insufficient processing resources to install the image.
0xC001	Unable to parse the image file. The image is not installed.

A successful C-Store operation indicates the image was written to the Merge Cardio Workstation's local file system. A patient and study level is created for the first image that belongs to a new study on the local file system. The new study will appear on the study list view when the first image for a new study is successfully installed on the local file system

A series level is also created for the first image that belongs to a new series within the study. In addition, an icon image will be present for each image that locally resides in the study on the study information view.

k. Presentation Context Acceptance Criterion

Each abstract syntax provided in the incoming request is compared to the list of presentation context items in the following tables, "Accepted Presentation Contexts" on page 27. If the abstract syntax matches an abstract syntax in the list, then the transfer syntax list is checked for a match. Each matching abstract syntax and transfer syntax pair is returned as one accepted presentation context to the requester.

l. Transfer Syntax Selection Policies

The JPEG process 14 transfer syntax is preferred over the little endian implicit VR (baseline) transfer syntax for the X-Ray Image Storage Abstract Syntax. If offered a choice of Transfer Syntaxes in a Presentation Context, it will apply the following priority to the selection(s) of Transfer Syntax:

JPEG lossless Process 14

Implicit VR Little Endian

Explicit VR Little Endian

For single frameSecondary Capture Image storage abstract syntax, if offered a choice of Transfer Syntaxes in a Presentation Context, it will apply the following priority to the selection(s) of Transfer Syntax:

Implicit VR Little Endian

Explicit VR Little Endian

Explicit VR Big Endian

m. Real World Activity “Storage Commitment Service”

n. Associated Real-World Activity

When the Merge Cardio Workstation receives a Storage Commitment request, it checks the list of SOP Instance UIDs in the request to determine which images are installed on the local file system. A Storage Commitment response is returned to the SCU with the list of SOP Instance UIDs and their individual pass/fail status.

o. Accepted Presentation Contexts

The following table illustrates the accepted presentation context for the Storage Commitment service class.

Abstract Syntax		Transfer Syntax		Role	Extended Negotiation
Name	UID	Name	UID		
Storage Commit Push Model	1.2.840.10008.1.20.1	Implicit VR Little Endian	1.2.840.10008.1.2	SCP	None

p. SOP-Specific Conformance

The Merge Cardio Workstation provides standard conformance to the Storage Commitment Push Model of the service class. The Storage Commitment Pull Model is not supported.

Upon receipt of the Storage Commit N-ACTION request, the Merge Cardio Workstation determines the existence of each SOP instance specified in the N-ACTION. After sending the N-ACTION response, the corresponding N-EVENT-REPORT is sent over a new association. The N-EVENT-REPORT specifies if each SOP instance specified in the N-ACTION currently exists on the Merge Cardio Workstation local storage.

The Merge Cardio Workstation maintains a user visible study level status field that may contain the following values. Please refer to the Merge Cardio Workstation operator’s manual for a complete description of the study status field.

Study Status	Description
Open	A storage commit N-ACTION request where all SOP instances in the request were present on the Merge Cardio Workstation local storage has not been received.
Complete	A storage commit N-ACTION request where all SOP instances in the request were present on the Merge Cardio Workstation local storage has been received. The Merge Cardio Workstation assumes that all SOP instances in a storage commit request belong to the same study.
Saved	The study was saved to removable media (STD-XA1K-CD / DVD or STD-US-CD / DVD profile) while the study status was Open. Not guaranteed to contain all of the images acquired for the patient.
Archived	The study was saved to removable media (STD-XA1K-CD / DVD or STD-US-CD / DVD profile) while the study status was Complete.

The following optional attributes are not supported in the N-ACTION request.

Tag	Description
(0008,0054)	Retrieve AE Title
(0088,0130)	Storage Media File-Set ID
(0088,0140)	Storage Media File-Set UID

q. Presentation Context Acceptance Criterion

Not Applicable.

r. Transfer Syntax Selection Policies

Not Applicable.

s. Real World Activity “Query Server”

t. Associated Real-World Activity

The Merge Cardio Workstation is always ready to accept a new transport connection and create a thread to process the Query (C-Find) request. The Merge Cardio Workstation will accept the presentation context associated with the Query request and send a response for each study, series or image that matches the keys provided in the Query request. The Query Server supports study, series and image level queries.

u. Accepted Presentation Contexts

The following table illustrates the proposed presentation context for the Find Study user request.

Abstract Syntax		Transfer Syntax		Role	Extended Negotiation
Name	UID	Name	UID		
Study Root Query Retrieve Information Model (C-Find)	1.2.840.10008.5.1.4.1.2.2.1	Implicit VR Little Endian	1.2.840.10008.1.2	SCP	None

The following table illustrates the proposed presentation context for the Retrieve user request.

Abstract Syntax		Transfer Syntax		Role	Extended Negotiation
Name	UID	Name	UID		
Study Root Query Retrieve Information Model (C-Move)	1.2.840.10008.5.1.4.1.2.2.2	Implicit VR Little Endian	1.2.840.10008.1.2	SCP	None

v. Specific Conformance for the Query (C-Find) SOP Class

The Merge Cardio Workstation conforms to the definition of an SCP of the Query (C-Find) Service in accordance with the DICOM standard. The Merge Cardio Workstation supports queries against the Study Root Information Model.

The Merge Cardio Workstation supports queries at the STUDY level in the Study Root FIND SOP class using the keys the following table:

Tag	Attribute Name
(0008,0020)	Study Date
(0008,0030)	Study Time
(0008,0050)	Accession Number
(0008,0061)	Modalities in Study
(0008,0090)	Referring Physician
(0008,1050)	Performing Physician's Name
(0010,0010)	Patient Name
(0010,0020)	Patient ID
(0010,0021)	Issuer of Patient ID
(0010,0030)	Patient DOB
(0010,0040)	Patient Sex
(0020,000D)	Study Instance UID
(0020,0010)	Study ID

The Merge Cardio Workstation supports queries at the SERIES level using the keys the following table:

Tag	Attribute Name
(0008,0060)	Modality
(0020,000e)	Series Instance UID
(0020,0011)	Series Number

The Merge Cardio Workstation supports queries at the IMAGE level using the keys in the following table:

Tag	Attribute Name
(0008,0018)	Image Instance UID
(0020,0013)	Image Number

w. Specific Conformance for the Retrieve (C-Move) SOP Class

The Merge Cardio Workstation conforms to the definition of an SCP of the Retrieve (C-Move) Service in accordance with the DICOM standard. The Merge Cardio Workstation supports retrievals against the Study Root Information Model.

2.5. Communication Profiles

TCP/IP is the only protocol stack supported.

2.5.1. Supported Communication Stacks (parts 8,9)

2.5.2. TCP/IP Stack

The TCP/IP stack as supported by the Windows Operating System.

2.5.3. API

N/A

2.5.4. Physical Media Support

Supported physical media include:

- 10BASE-T
- 100BASE-TX
- 1000BASE-T

2.6. Extensions/Specializations/Privatizations

2.6.1. Standard Extended/Specialized Private SOP

Not Applicable.

2.6.2. Private Transfer Syntaxes

Not Applicable.

2.7. Configuration

The table below lists the application-wide DICOM-related configurable parameters.

Parameter	Notes
Institution Name	Written on all image SOP instances created
Institution Address	Written on all image SOP instances created

The table below lists the DICOM-related parameters that are configurable for each DICOM Application Entity (i.e., both Local and Remote)

Parameter	Parameter Subtype	Notes
AE Alias		User visible name associated with the AE title.
AE Title		Max 16 alphanumeric characters
IP Address		Dotted decimal format. An internet host name address is also allowed.
TCP Port		104 is the default.
Lab Name		Associate the configured lab name with the AE Title.
Query Service Provider		Boolean value.
	Default	Boolean value. Default query service provider displayed on Find Study dialog.
	ImageLevel	Boolean value. Query Server that supports series and image level queries
Storage Service Provider		Boolean value.
	Default	Boolean value. Default storage service provider displayed on Send Study dialog.
	AutoForward	Boolean value. All received images are automatically forwarded to this destination
	BaselineOnly	Boolean value. Storage Server that does not support JPEG frame data
	Primary Archive	Boolean value.
	XA Only	Boolean value. Storage Server that does not support Secondary Capture images

2.7.1. Support of Extended Character Sets

The ISO-IR 100 (ISO 8859-1:1987 Latin alphabet N 1, supplementary set) is supported.

Chapter 3. SC Information Object Implementation

3.1. Introduction

This section specifies the use of the DICOM Secondary Capture Image IOD to represent the information included in Secondary Capture Images produced by this implementation. Corresponding attributes are conveyed using the modules construct.

3.2. SC Image IOD Implementation

This section defines the implementation of the SC image information object. It refers to the DICOM Standard, Part 3 (Information Object definition).

3.3. SC Image IOD Entities

3.3.1. Entities Description

Refer to DICOM Standard, Part 3 (Information Object Definitions) for a description of the entities contained within this information object.

3.4. SC Image IOD Module Table

The table below identifies the defined modules within the entities that comprise the DICOM Secondary Capture Image Information Object Definition. Modules are defined by Module Name.

See DICOM Part 3 for a complete definition of the entities, modules and attributes that comprise this IOD.

Information Entity	Module Name	Reference
Patient	Patient	“Patient Module Attributes” on page 41
Study	General Study	“General Study Module Attributes” on page 42
	Patient Study	“Patient Study Module Attributes” on page 42
Series	General Series	“General Series Module Attributes” on page 42
Equipment	General Equipment	“General Equipment Module Attributes” on page 43
	SC Equipment	“Secondary Capture Equipment Module Attributes” on page 44

Information Entity	Module Name	Reference
Image	General Image	“General Image Module Attributes” on page 44
	Image Pixel	“Image Pixel Module Attributes” on page 45
	SC Image	“SC Image Module Attributes” on page 46
	Overlay Plane	Not used
	Modality LUT	Not Used
	VOI LUT	“VOI LUT Module Attributes” on page 46
	SOP Common	“SOP Common Module Attributes” on page 46

3.5. Information Module Definitions

Please refer to the DICOM Standard, Part 3 for a description of each of the entities and modules contained within the Secondary Capture Information Object.

3.5.1. Patient Entity Module

a. Patient Module Attributes

Attribute Name	Tag	Type	Attribute Description
Patient Name	(0010,0010)	2	Use original image value
Patient ID	(0010,0020)	2	Use original image value
Issuer of Patient ID	(0010,0021)	3	Use original image value
Patient Birthdate	(0010,0030)	2	Use original image value
Patient Sex	(0010,0040)	2	Use original image value
Referenced Patient Sequence	(0008,1120)	3	Not used
>Referenced SOP Class UID	(0008,1150)	1C	Not used
>Referenced SOP Instance UID	(0008,1155)	1C	Not used
Patient’s Birth Time	(0010,0032)	3	Use original image value
Other Patient Ids	(0010,1001)	3	Use original image value
Ethnic Group	(0010,2160)	3	Not used
Patient Comments	(0010,4000)	3	Use original image value

3.5.2. Study Entity Module

a. General Study Module Attributes

Attribute Name	Tag	Type	Attribute Description
Study Instance UID	(0020,000D)	1	Use original image value
Study Date	(0008,0020)	2	Use original image value
Study Time	(0008,0030)	2	Use original image value
Referring Physician's Name	(0008,0090)	2	Use original image value
Study ID	(0020,0010)	2	Use original image value
Accession Number	(0008,0050)	2	Use original image value
Study Description	(0008,1030)	3	Use original image value
Physician's of Record	(0008,1048)	3	Use original image value
Name of Physician Reading Study	(0008,1060)	3	Not used
Referenced Study Sequence	(0008,1110)	3	Not used
>Referenced SOP Class UID	(0008,1150)	1C	Not used
>Referenced SOP Instance UID	(0008,1155)	1C	Not used

b. Patient Study Module Attributes

Attribute Name	Tag	Type	Attribute Description
Admitting Diagnoses Description	(0008,1080)	3	Not used
Patient's Age	(0010,1010)	3	Not used
Patient's Size	(0010,1020)	3	Use original image value
Patient's Weight	(0010,1030)	3	Use original image value
Occupation	(0010,2180)	3	Not used
Additional Patient's History	(0010,21B0)	3	Not used

3.5.3. Series Entity Module

a. General Series Module Attributes

Attribute Name	Tag	Type	Attribute Description
Modality	(0008,0060)	1	Use original image value
Series Instance UID	(0020,000E)	1	Use original image value

Attribute Name	Tag	Type	Attribute Description
Series Number	(0020,0011)	2	Use original image value
Laterality	(0020,0060)	2C	Not used
Series Date	(0008,0021)	3	Not used
Series Time	(0008,0031)	3	Not used
Performing Physician's Name	(0008,1050)	3	Use original image value
Protocol Name	(0018,1030)	3	Not used
Series Description	(0008,103E)	3	Not used
Operator's Name	(0008,1070)	3	Not used
Referenced Study Component Sequence	(0008,1111)	3	Not used
>Referenced SOP Class UID	(0008,1150)	1C	Not used
>Referenced SOP Instance UID	(0008,1155)	1C	Not used
Body Part Examined	(0018,0015)	3	Not used
Patient Position	(0018,5100)	2C	Not used
Smallest Pixel Value in Series	(0028,0108)	3	Not used
Largest Pixel Value in Series	(0028,0109)	3	Not used

3.5.4. Equipment Entity Module

a. General Equipment Module Attributes

Attribute Name	Tag	Type	Attribute Description
Manufacturer	(0008,0070)	2	Use original image value
Institution Name	(0008,0080)	3	Use original image value
Institution Address	(0008,0081)	3	Use original image value
Station Name	(0008,1010)	3	Use original image value
Institutional Department Name	(0008,1040)	3	Not used
Manufacturer's Model Name	(0008,1090)	3	Use original image value
Device Serial Number	(0018,1000)	3	Not used
Software Version	(0018,1020)	3	Not used
Spatial Resolution	(0018,1050)	3	Not used
Date of Last Calibration	(0018,1200)	3	Not used

Attribute Name	Tag	Type	Attribute Description
Time of Last Calibration	(0018,1201)	3	Not used
Pixel Padding Value	(0028,0120)	3	Not used

b. Secondary Capture Equipment Module Attributes

Attribute Name	Tag	Type	Attribute Description
Conversion Type	(0008,0064)	1	“WSD”
Modality	(0008,0060)	3	Use original image value
Secondary Capture Device ID	(0018,1010)	3	Not used
Secondary Capture Device Manufacturer	(0018,1016)	3	Not used
Secondary Capture Device Manufacturer’s Model Name	(0018,1018)	3	Not used
Secondary Capture Device Software Version	(0018,1019)	3	Not used
Video Image Format Acquired	(0018,1022)	3	Not used
Digital Image Format Acquired	(0008,1023)	3	Not used

3.5.5. Image Entity Module

a. General Image Module Attributes

Attribute Name	Tag	Type	Attribute Description
Image Number	(0020,0013)	2	Use original image value
Patient Orientation	(0020,0020)	2C	Zero Length
Image Date	(0008,0023)	2C	The date image captured
Image Time	(0008,0033)	2C	The time image captured
Image Type	(0008,0008)	3	DERIVED\SECONDARY\ SINGLE PLANE
Acquisition Number	(0020,0012)	3	Use original image value
Acquisition Date	(0008,0022)	3	Not used
Acquisition Time	(0008,0032)	3	Not used
Reference Image Sequence	(0008,1140)	3	Not used
>Referenced SOP Class UID	(0008,1150)	1C	Not used
>Referenced SOP Instance UID	(0008,1155)	1C	Not used

Attribute Name	Tag	Type	Attribute Description
Derivation Description	(0008,2111)	3	Not used
Source Image Sequence	(0008,2112)	3	Not used
>Referenced SOP Class UID	(0008,1150)	1C	Not used
>Referenced SOP Instance UID	(0008,1155)	1C	Not used
Images in Acquisition	(0020,1002)	3	Not used
Image Comments	(0020,4000)	3	If Primary Image, Comment = "Created from Seq" or "Created from Sequence" + original frame number; If Secondary Image, comment = "Created from Photo" + original frame number
Lossy Image Compression	(0028,2110)	3	Use original image value

b. Image Pixel Module Attributes

Attribute Name	Tag	Type	Attribute Description
Samples Per Pixel	(0028,0002)	1	1
Photometric Interpretation	(0028,0004)	1	Use original image value
Rows	(0028,0010)	1	1024
Columns	(0028,0011)	1	1024
Bits Allocated	(0028,0100)	1	8
Bits Stored	(0028,0101)	1	8
High Bit	(0028,0102)	1	7
Pixel Representation	(0028,0103)	1	0
Pixel Data	(7FE0,0010)	1	
Planar Configuration	(0028,0006)	1C	Not used
Pixel Aspect Ratio	(0028,0034)	1C	Use original image value
Smallest Image Pixel Value	(0028,0106)	3	Not used
Largest Image Pixel Value	(0028,0107)	3	Not used
Red Palette Color LUT Descriptor	(0028,1101)	1C	Not used
Blue Palette Color LUT Descriptor	(0028,1102)	1C	Not used
Green Palette Color LUT Descriptor	(0028,1103)	1C	Not used
Red Palette Color LUT Data	(0028,1201)	1C	Not used

Attribute Name	Tag	Type	Attribute Description
Blue Palette Color LUT Data	(0028,1202)	1C	Not used
Green Palette Color LUT Data	(0028,1203)	1C	Not used

c. SC Image Module Attributes

Attribute Name	Tag	Type	Attribute Description
Date of Secondary Capture	(0018,1012)	3	Date image is captured
Time of Secondary Capture	(0018,1014)	3	time image is captured

d. VOI LUT Module Attributes

Attribute Name	Tag	Type	Attribute Description
Window Center	(0028,1050)	3	Not used
Window Width	(0028,1051)	3	Not used

e. SOP Common Module Attributes

Attribute Name	Tag	Type	Attribute Description
Specific Character Set	(0008,0005)	3	Use original image value
SOP Class UID	(0008,0016)	1	1.2.840.10008.5.1.4.1.1.7
SOP Instance UID	(0008,0018)	1	1.2.840.113697.6.5 + machine serial number + time + series number + image number
Instance Creation Date	(0008,0012)	3	Not Used
Instance Creation Time	(0008,0013)	3	Not Used
Instance Creator UID	(0008,0014)	1	1.2.840.113697.6.3. + machine serial number

Chapter 4. Print Management Specific Modules

4.1. Introduction

The following sections specify the default and User optional attributes that can be set in the modules used for Print Management.

4.1.1. Basic Film Session Presentation Module Attributes

Attribute Name	Tag	Type	Attribute Description
Number of Copies	(2000,0010)	U	User Configurable: 1 (default) - 10
Print Priority	(2000,0020)	U	Not used
Medium Type	(2000,0030)	U	Not used
Film Destination	(2000,0040)	U	Not used
Film Session Label	(2000,0050)	U	Not used
Memory Allocation	(2000,0060)	U	Not used
Owner ID	(2100,0160)	U	Not used

4.1.2. Basic Film Box Presentation Module Attributes

Attribute Name	Tag	Type	Attribute Description
Image Display Format	(2010,0010)	U	STANDARD\1,1 – default STANDARD\1,2 STANDARD\2,1 STANDARD\2,2 STANDARD\3,2 STANDARD\3,3 STANDARD\3,4 STANDARD\4,3 STANDARD\4,4
Annotation Display Format ID	(2010,0030)	U	Not used
Film Orientation	(2010,0040)	U	User Configurable: PORTRAIT – default LANDSCAPE
Film Size ID	(2010,0050)	U	Not used
Magnification Type	(2010,0060)	U	Not used

Attribute Name	Tag	Type	Attribute Description
Smoothing Type	(2010,0080)	U	Not used
Border Density	(2010,0100)	U	User Configurable: WHITE – default BLACK
Empty Image Density	(2010,0110)	U	User Configurable: WHITE – default BLACK
Minimum Density	(2010,0120)	U	Not used
Maximum Density	(2010,0130)	U	Not used
Trim	(2010,0140)	U	User Configurable: YES – default NO
Configuration Information	(2010,0150)	U	Not used
Illumination	(2010,015E)	U	Not used
Reflected Ambient Light	(2010,0160)	U	Not used
Requested Resolution ID	(2020,0050)	U	Not used

4.1.3. Image Box Pixel Presentation Module Attributes

Attribute Name	Tag	Type	Attribute Description
Polarity	(2020,0020)	U	User Configurable: NORMAL – default REVERSE
Magnification Type	(2010,0060)	U	Not used
Smoothing Type	(2010,0080)	U	Not used
Configuration Information	(2010,0150)	U	Not used
Requested Image Size	(2020,0030)	U	Not used
Requested Decimate/Crop Behavior	(2020,0040)	U	Not used
Basic Grayscale Image Sequence	(2020,0100)	M	
> Samples Per Pixel	(0028,0002)	M	1
> Photometric Interpretation	(0028,0004)	M	MONOCHROME2
> Rows	(0028,0010)	M	954
> Columns	(0028,0011)	M	1024
Pixel Aspect Ratio	(0028,0034)	M	1:1
Bits Allocated	(0028,0100)	M	8

Attribute Name	Tag	Type	Attribute Description
Bits Stored	(0028,0101)	M	8
High Bit	(0028,0102)	M	7
Pixel Representation	(0028,0103)	M	0
Pixel Data	(7FE0,0010)	M	
Basic Color Image Sequence	(2020,0111)	M	
> Samples Per Pixel	(0028,0002)	M	3
> Photometric Interpretation	(0028,0004)	M	RGB
> Planar Configuration	(0028,0006)	M	Color by Plane - 1
> Rows	(0028,0010)	M	954
> Columns	(0028,0011)	M	1024
Pixel Aspect Ratio	(0028,0100)	M	1:1
Bits Allocated	(0028,0101)	M	8
Bits Stored	(0028,0101)	M	8
High Bit	(0028,0102)	M	7
Pixel Representation	(0028,0103)	M	0
Pixel Data	(7FE0,0010)	M	

Chapter 5. Media Storage Conformance Statement

5.1. Introduction

The remainder of this document specifies the Merge Cardio Workstation compliance to DICOM media interchange.

The Merge Cardio Workstation provides the user with the ability to review, load, and author DICOM-compliant CD and DVD media. This document covers Workstation conformance to DICOM Media Storage Application Profiles.

All of the DICOM features presented in this document are optional and may not be available on all Workstations.

5.2. Implementation Model

5.2.1. Application Data Flow Diagram

The media specific implementation model for the Merge Cardio Workstation is shown below.

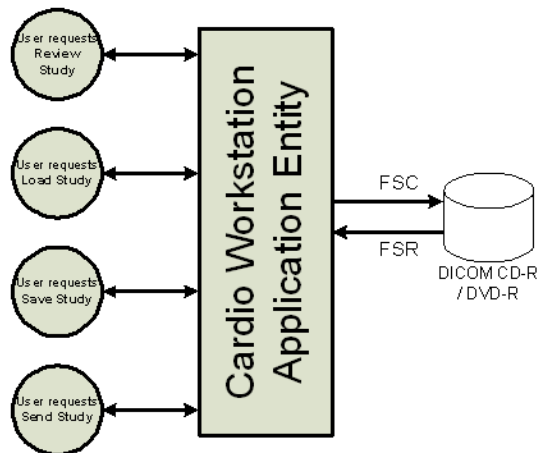

5.2.2. Functional Definition of AEs

The Merge Cardio Workstation application provides the following media related DICOM functionality to the user:

- Review a study directly from CD / DVD media.
- Load a study (STD-XABC-CD / DVD, STD-XA1K-CD / DVD, AUG-SC-STD-US-CD / DVD, STD-GEN-CD / DVD, STD-GEN-DVD-JPEG profiles) on media to local storage.
- Save a study (STD-XABC-CD / DVD, STD-XA1K-CD / DVD, AUG-SC-STD-US-CD / DVD, STD-GEN-CD / DVD, STD-GEN-DVD-JPEG profiles) on the local file system to media.

NOTE: Saving a study to Media requires a CD / DVD or DVD Writer that is an option and requires a license.

5.2.3. Sequencing of Real-World Activities

Not Applicable.

5.2.4. File Meta Information for Implementation Class and Version

The following Meta information attributes pertain to the implementation class and version.

Tag	Name	Value
(0002,0001)	File Meta Information Version	1
(0002,0012)	Implementation Class UID	1.2.840.113697.6.8
(0002,0013)	Implementation Version Name	Syntax: <major revision>.<minor revision>.<validation cycle>.<verification cycle>

5.3. AE Specifications

5.3.1. Workstation AE Specification

The Merge Cardio Workstation provides standard conformance to the DICOM Interchange Option of the Media Storage Service Class. The application profiles and roles are listed in the table below.

Supported Application Profile	Real-World Activity	Roles	SC Option
STD-XABC-CD / DVD	Review study from CD / DVD	FSR	Interchange with directory information module
	Load study from CD / DVD	FSR	Interchange with directory information module
	Save study to CD / DVD	FSC	Interchange with directory information module
	Send study from CD / DVD	FSR	Interchange with directory information module
STD-XA1K-CD / DVD	Review study from CD / DVD	FSR	Interchange with directory information module
	Load study from CD / DVD	FSR	Interchange with directory information module
	Save study to CD / DVD	FSC	Interchange with directory information module
	Send study from CD / DVD	FSR	Interchange with directory information module

Supported Application Profile	Real-World Activity	Roles	SC Option
AUG-SC-STD-US-CD / DVD	Review study from CD / DVD	FSR	Interchange with directory information module
	Load study from CD / DVD	FSR	Interchange with directory information module
	Save study to CD / DVD	FSC	Interchange with directory information module
	Send study from CD / DVD	FSR	Interchange with directory information module
STD-GEN-DVD-JPEG	Review study from CD / DVD	FSR	Interchange with directory information module
	Load study from CD / DVD	FSR	Interchange with directory information module
	Save study to CD / DVD	FSC	Interchange with directory information module
	Send study from CD / DVD	FSR	Interchange with directory information module

The Merge Cardio Workstation performs one or more of the following actions automatically when media are placed in the CD / DVD Reader drive:

- Displays one line on the study list screen for each supported study on the if a valid DICOMDIR file is found in the root directory.
- Displays a warning message if an invalid DICOMDIR file is found in the root directory.
- Performs no action if a DICOMDIR file is not detected in the root directory.

a. File Meta Information for the Merge Cardio Workstation AE

The following Meta information attributes applies to a particular Workstation AE:

Tag	Name	Value
(0002,0016)	Source Application Entity Title	<configurable on the Merge Cardio Workstation>

5.3.2. Real World Activities

a. Real World Activity “Display Study Information from CD / DVD”

The Merge Cardio Workstation AE implements the FSR role using the interchange option when requested to display study information for a study residing on CD / DVD media. A tree view is displayed representing the DICOMDIR file on the CD / DVD media.

b. Media Storage Application Profile

Study information may be displayed from CD / DVDs that conform to the STD-XABC-CD / DVD, STD-XA1K-CD / DVD or AUG-SC-STD-US-CD / DVD, STD-GEN-CD / DVD, STD-GEN-DVD-JPEG application profile.

c. Real World Activity “Review Study from CD / DVD”

The Merge Cardio Workstation AE implements the FSR role using the interchange option when requested to review a study residing on media.

d. Media Storage Application Profile

Studies may be reviewed from media that conform to the STD-XABC-CD / DVD, STD-XA1K-CD / DVD or AUG-SC-STD-US-CD / DVD, STD-GEN-CD / DVD, STD-GEN-DVD-JPEG application profile.

e. Real World Activity “Load Study from CD / DVD”

The Merge Cardio Workstation AE implements the FSR role using the interchange option when requested to load a study from media. Any study on the CD / DVD that contains image SOP instances supported by the STD-XABC-CD / DVD, STD-XA1K-CD / DVD, AUG-SC-STD-US-CD / DVD, STD-GEN-CD / DVD, STD-GEN-DVD-JPEG application profile may be loaded to the local file system. Only supported images within the study are loaded.

f. Media Storage Application Profile

Studies may be loaded to the local file system from media that conform to the STD-XABC-CD / DVD, STD-XA1K-CD / DVD, AUG-SC-STD-US-CD / DVD, STD-GEN-CD / DVD, STD-GEN-DVD-JPEG application profile.

g. Real World Activity “Save Study to CD / DVD”

The Merge Cardio Workstation AE implements the FSC role using the interchange option when requested to save a study on the local file system to media. The user is required to insert blank media into the recorder drive.

The images belonging to the studies determine the application profile being recorded. Please reference DICOM Part 11 for the detailed specifications of a particular application profile. The User Interface provides two icons – “Create Exchange CD / DVD” and “Create Archive CD / DVD”. When the User selects the “Create Exchange CD / DVD” icon, a CD / DVD is created that conforms to the STD-XABC-CD / DVD profile. When the User selects the “Create Archive CD / DVD” icon, a CD / DVD is created that conforms either to the STD-XA1K-CD / DVD or AUG-SC-STD-US-CD / DVD, STD-GEN-CD / DVD, STD-GEN-DVD-JPEG depending on the type of images in the study.

NOTE: Merge has defined a mechanism to record a study larger than the capacity of any one medium to a set of CDs or DVDs. A label is recorded on each medium indicating the order number and the total number of CDs or DVDs that represents the complete study. When a multi-CD / DVD study is loaded, the user will be prompted to load all CD / DVDs representing the original study.

h. Media Storage Application Profile

Studies may be saved to media that conform to the STD-XABC-CD / DVD, STD-XA1K-CD / DVD or AUG-SC-STD-US-CD / DVD, STD-GEN-CD / DVD, STD-GEN-DVD-JPEG application profile.

5.4. Augmented and Private Application Profiles

5.4.1. Augmented Application Profiles

The Merge Cardio Workstation supports one augmented Application profile: AUG-SC-STD-US-CD / DVD.

a. AUG-SC-STD-US-CD / DVD

This application profile is an augmentation of the STD-US-CD / DVD standard application profile. The augmentation adds support for the SC SOP class.

b. SOP class Augmentation

The following SOP is part of the AUG-SC-STD-US-CD / DVD application profile. There are no requirements or restrictions on SOP options beyond those in the standard definitions.

Service Object Pair		Transfer Syntax	
Name	UID	Name	UID
Secondary Capture Image Storage	1.2.840.10008.5.1.4.1.1.7	Explicit VR Little Endian	1.2.840.10008.1.2.1

5.4.2. Private Application Profiles

Not Applicable.

5.5. Extensions, Specializations, Privatizations of SOP Classes, and Transfer Syntaxes

5.5.1. Extensions, Specializations, and Privatizations of SOP Classes

a. SOP-Specific Conformance Statement for “Media Storage Directory Storage”

The Merge Cardio Workstation supports additional type 3 attributes at the patient, study, series, and image levels in the Basic Directory IOD. Please refer to DICOM Part 3 for a complete description of the Basic Directory Information Object.

b. Basic Directory IOD - File-Set Identification Module

The following file-set identification module attributes are of special interest.

Tag	Name	Notes
(0004,1130)	File Set ID	The Merge Cardio Workstation allows the user to fill in the value of this data element. The “file set ID” label is analogous to a cine film can label.

c. Basic Directory IOD – Optional Patient Keys

In addition to the required type 1 and type 2 keys, the following standard type 3 keys are supported at the patient level if the key has a data value.

Tag	Name
(0010,0030)	Birth Date
(0010,0040)	Sex
(0010,4000)	Patient Comments

d. Basic Directory IOD – Optional Study Keys

In addition to the required type 1, type 1C and type 2 keys, the following standard type 3 keys are supported at the study level if the key has a data value.

Tag	Name
(0008,0090)	Referring Physician
(0010,1020)	Patient’s Height
(0010,1030)	Patient’s Weight
(0032,4000)	Study Comments

e. Basic Directory IOD – Optional Series Keys

In addition to the required type 1, type 1C and type 2 keys, the following standard type 3 keys are supported at the series level if the key has a data value.

Tag	Name	Notes
(0008,0070)	Manufacturer	
(0008,0080)	Institution Name	<configurable on the Merge Cardio Workstation>
(0008,0081)	Institution Address	<configurable on the Merge Cardio Workstation>
(0008,1010)	Station Name	
(0008,1050)	Performing Physician’s Name	

f. Basic Directory IOD – Optional Image Keys

In addition to the required type 1, type 1C and type 2 keys, the following standard type 3 keys are supported at the image level if the key has a data value.

Tag	Name	Notes
(0008,0008)	Image Type	
(0008,0022)	Acquisition Date	
(0008,0023)	Image Date	
(0008,0032)	Acquisition Time	
(0008,0033)	Image Time	
(0008,1140)	Referenced Image Sequence	if image type specifies BIPLANE A or BIPLANE B image
(0020,0012)	Acquisition Number	
(0020,4000)	Image Comments	
(0028,0004)	Photometric Interpretation	
(0028,0008)	Number of Frames	
(0028,0010)	Number of Rows	
(0028,0011)	Number of Columns	
(0028,0034)	Pixel Aspect Ratio	
(0028,0100)	Bits Allocated	
(0028,0101)	Bits Stored	
(0028,1040)	Pixel Intensity Relationship	
(0028,6010)	Representative Frame Number	
(0050,0004)	Calibration Image	
(0088,0200)	Icon Image Sequence	

5.5.2. Private Transfer Syntax Specification

Not Applicable.

5.6. Configuration

The following DICOM-related data elements are configurable on the Merge Cardio Workstation as well as recorded on any CD / DVD-R authored media:

Tag	Name
(0002,0016)	Source Application Entity Title
(0008,0080)	Institution Name
(0008,0081)	Institution Address

5.7. Support of Extended Character Sets

The ISO-IR 100 (ISO 8859-1:1987 Latin alphabet N 1, supplementary set) is supported.